



Rhythm  **:ds32**
High Resolution
Auscultation

**Digital
Electronic
Stethoscope**

User's Manual



Table of Contents

3	Thinklabs Rhythm Digital Stethoscopes
3	Indications for Use
4	Caution - Follow Directions for Use
4	Optimal Use of the ds32
5	Quick Reference - Controls and Display
6	Initial Setup
6	Installing Batteries
7	Battery Life and the Low Battery Indicator
8	Probe Setup
9	Using the ds32
9	Control Ergonomics
10	Power On/Off
11	Zoom and Volume Control
	Volume Settings and Psychoacoustics
12	Bell-Diaphragm Mode
	Auscultation - a Pathology-Physiology Dichotomy
13	Sync Indicator
	Using Sync
14	Input/Output Port
	Using the Audio Input/Output Port
15	Optimizing the ds32
15	General Maintenance and Cleaning
16	Eartip Adjustment
17	Headphone Adjustment
18	Listening with the ds32
	Diaphragm Pressure and Frequency Response
	Holding the Probe - steady pressure reduces sub-sonics
19	Diaphragm Selection
	The Diaphragm - fine-tuning your stethoscope sound
20	Diaphragm Changing and Replacement
21-22	Probe Maintenance - ensuring low-noise performance
	Noise Symptoms
	Alcohol Cleaning
	Air Spray Cleaning
23	Eartip Cleaning and Replacement
24-25	Tips and Troubleshooting
26	Service and Warranty Information
26	Package Contents List



Thinklabs Rhythm Digital Stethoscopes

Congratulations on purchasing your ds32. You now own an instrument designed for high resolution auscultation - an instrument that produces body sounds with low-noise and high-amplification, providing a new level of clarity.

Your **ds32** includes the following features:

- **Power:** Zoom Adjustable Volume mode provides low distortion, high power amplification, while standard Acoustic power mode provides the familiar sound of a conventional acoustic stethoscope. Both modes utilize signal processing designed to provide very high signal definition.
- **Ease-of-Use:** Simple controls provide familiar Diaphragm and Bell modes at either standard Acoustic or Zoom power levels, with mode changes at the push of a button.
- **Patented Transducer:** The Electromagnetic Diaphragm™ (EmD) senses and converts body sounds to electronic signals right at the diaphragm, eliminating signal degradation through air-borne transducers or tubing. The EmD is pressure-modulated. By subtle variation of Probe pressure, amplitude and frequency response can be tuned to listen to specific sounds. This is even provided in standard Acoustic mode, combining familiar acoustics with advanced signal processing.
- **Sync:** LED Indicator shows cardiac cycle timing to help students improve auscultation skills.
- **Audio Port:** An Input/Output port provides an audio line-level output signal or use of the ds32 as headphones suited to listening to recorded auscultation sounds.
- **Design:** All these features are packaged in a stethoscope that has the form factor and weight of an instrument so familiar to the professional community of users.

Indications

The Thinklabs Rhythm Digital Stethoscope is intended for use as a diagnostic aid in patient diagnosis. It can be used for the amplification of heart, lung, and other body sounds with selective frequency filtering. This product is not designed, sold, or intended for any use except as indicated.



Caution - Follow Directions for Use

Misuse of this product could result in damage to the product, malfunction of the product, or compromise performance.

- Use only AAA Alkaline batteries. The Rhythm will not function if battery voltage is depleted. Use fresh batteries, and replace when indicated.
- Do not sterilize this device, or immerse it in liquids. Clean using alcohol swabs or non-abrasive cloth lightly dampened with alcohol or water.
- Avoid use/storage in very high humidity, high temperature or dusty conditions. Leaving the device in excessively hot or cold vehicles is NOT recommended.
- Do not attempt to modify or repair this device yourself. If you experience problems, send this device to Thinklabs for repair. See the Support page at <http://www.thinklabsmedical.com>
- The Thinklabs Rhythm stethoscope has been tested to be resistant to electromagnetic interference (EMI & ESD). However, it may be susceptible to stray electromagnetic fields. If unexpected sounds are heard, change location, or move away from possible sources of interference, such as cellular telephones or wireless devices.
- At the conclusion of this device's useful life, dispose or recycle in accordance with local regulations.

Optimal Use of the ds32

- **Instructions** - The ds32 is designed to be very easy-to-use. However, taking the time to read the User's Manual will greatly facilitate the effective and optimal use of the ds32. These instructions provide valuable tips that are well worth knowing, to get the most out of the ds32.
- **Sound Levels** - Adjust the Volume to a comfortable level. The ds32 has powerful amplification. Maximum volume is not necessary except when examining obese patients or in high-noise environments. Experiment to identify optimal settings and personal preferences.
- **Acoustic and Zoom Modes** - The ds32 has Acoustic mode, with more of a conventional stethoscope sound, and Zoom mode, which allows for adjustable volume levels. Both modes provide the clarity and benefits of Thinklabs electronic signal processing and amplification.
- **Diaphragm Pressure** - The ds32 Probe uses Electromagnetic Diaphragm (EmD) technology which is pressure-sensitive. The sound characteristics change as the Probe is applied with greater or lesser pressure to the patient. Simply apply the Probe to the patient as with a conventional stethoscope, and make subtle changes in pressure, listening for the optimal sound characteristics. Lighter pressure is usually optimal, and increases low frequency response to murmurs and heart sounds, while increased pressure will amplify lung sounds. Avoid unnecessary Probe movement, and apply steady diaphragm pressure.
- **Diaphragm Selection** - Two diaphragms are provided, with different sensitivity, to suit the personal preference of each practitioner. Experiment to find the optimal choice.
- **Skin Contact** - Always auscultate directly, not through clothing. The ds32's EmD diaphragm operates best when in direct skin contact with the patient.



Quick Reference - Controls and Display

Select Bell or Diaphragm
Green LEDs show selection
Page 12

Sync Indicator LED - S1/S2 Cardiac Timing
Push key to activate/deactivate
Page 13

Volume Control
behind Control Panel
(active when Blue LED is On)
Page 11

Control Panel



Power On
Push + Hold
until all LEDs light
then Release

Power Off
Shuts off after 120 seconds OR
Push + Hold
until all LEDs light
then Release

Page 10

Zoom - Select Pre-Set or Adjustable Volume
Push key to alternate between augmented Zoom mode
and pre-set non-augmented Acoustic mode:

Mode	Blue LED	Function
Zoom	ON	Augmented ADJUSTABLE Volume to "zoom in" by increasing Volume.
Acoustic	OFF	non-augmented PRE-SET Volume similar to acoustic stethoscope.

Page 11

Display

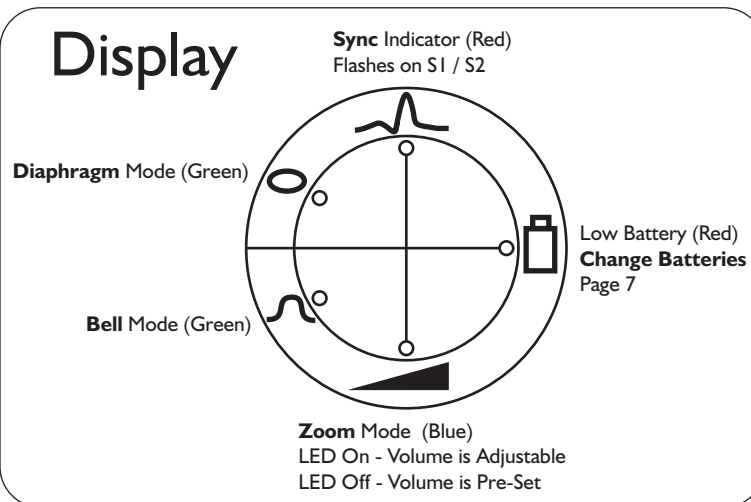



Initial Setup

Installing Batteries

Open the Battery Cover.

Hold the Control System Casing with two hands as shown. Slide the Battery Cover in the direction shown by the arrow, by using both thumbs placed on the Battery Cover sides as shown, or by using one thumb applied to the ribbed indentation in the center of the battery cover.

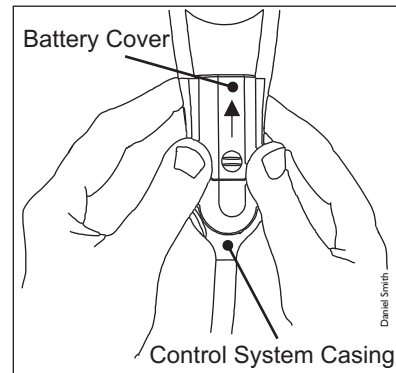

Insert 2 AAA Batteries as shown below. NOTE THE POLARITY - Reversing the polarity can cause damage to the ds32.

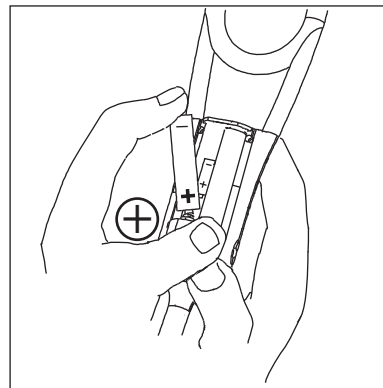
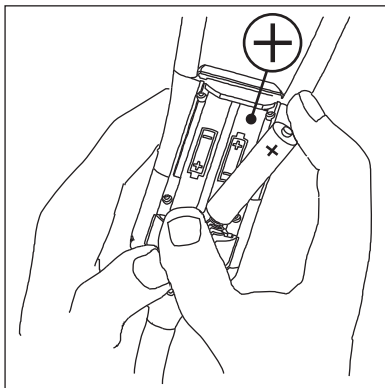

Compress the large battery spring sufficiently to ensure that the batteries are well-seated in the battery compartment, and that all springs connect with the battery contacts.

Use Alkaline Batteries only. Rechargeable batteries tend to have lower voltages even when fully charged, which might trigger a Low Battery indication even when the batteries are fully charged.

Close the Battery Cover.

Place the Battery Cover into the slide grooves, and slide the Battery Cover, using thumb and forefinger as shown, until fully closed. If the cover does not close easily, take care to ensure that the Battery Cover is pushed all the way into the grooves, and slides easily. Do not exert excessive force.

If your Rhythm does not operate after changing batteries, carefully recheck battery polarity, and ensure that fresh batteries are being used.

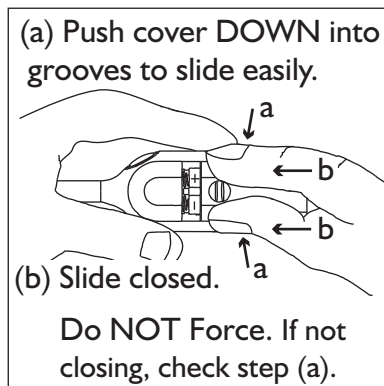



Battery Life and the Low Battery Indicator

The Low Battery Indicator on the display will show when the batteries require replacement. A red LED in the Low Battery Indicator signifies a low battery condition.

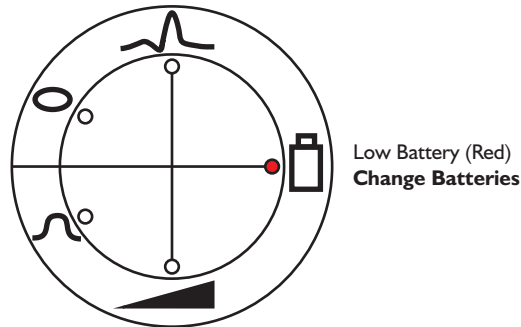

After a Low Battery indication initially occurs, the Rhythm will provide a few additional hours of operation, which should be sufficient for a few days of use in a typical work environment. It is recommended, however, that batteries be replaced within a day of the Low Battery Indicator warning, to ensure uninterrupted service.

When the batteries have become depleted beyond their useful life, the unit will fail to power up, or will power up and immediately power down, preventing further use. **The unit cannot be used in any mode without battery power.**

ds32 battery life is highly dependent on device use. Examining a large number of patients each day will naturally require more regular battery replacement than occasional use. Another important factor is the volume level and type of body sound. The ds32 has high current bass drive circuitry to reproduce powerful low frequency signals without distortion. This circuitry consumes more current when reproducing heart sounds in Bell mode compared with, say, listening to lung sounds in Diaphragm mode. It is for this reason that an exact battery life specification is not provided.



Probe Setup

The Probe has a black Acoustic Aperture ring which is shipped in the closed position. The Aperture should be left closed in most cases.

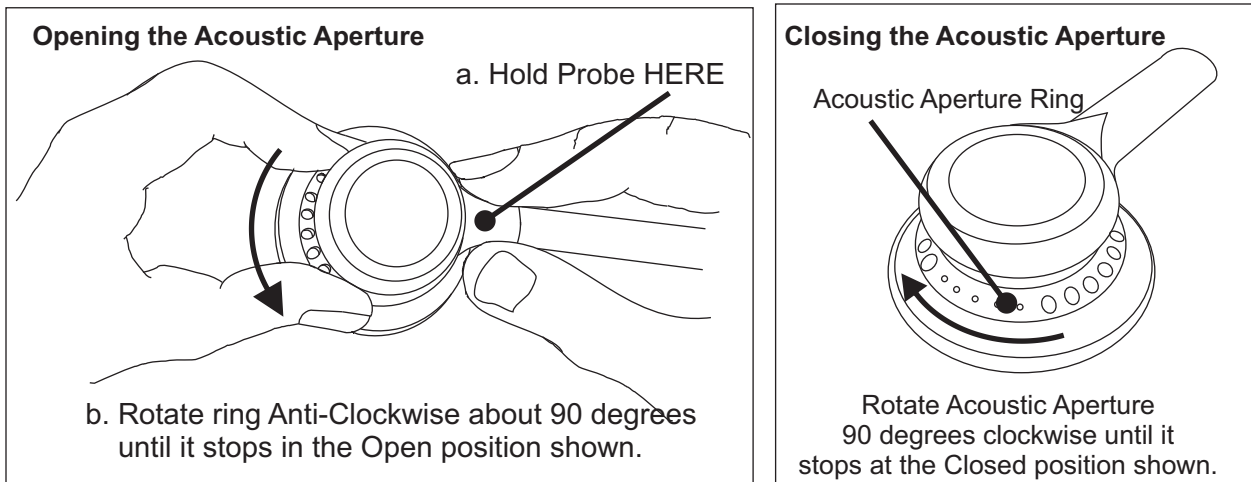

To open the Acoustic Aperture, rotate the ring anti-clockwise. To close, turn clockwise.

The Acoustic Aperture affects the Probe acoustics, subject to the environment in which the ds32 is used. In many situations, the audible differences are very subtle, and the Aperture Ring should then be kept closed to protect the Probe from dust and moisture. The effect of the Acoustic Aperture positions are as follows:

Aperture Closed - The Acoustic Aperture closes the internal Probe cavity, protecting it from dust and moisture, and producing a more “closed” tonality.

Aperture Open - When open, the Acoustic Aperture can improve the acoustics of the ds32 in certain environments. If you are using the ds32 in a high ambient noise environment, try opening the aperture ring. You may find that the more “open” sound is preferable. Then rotate the ring to the closed position when you return to a quiet environment.

Using the ds32 with open or closed aperture is a matter of personal preference.



Using the ds32

The ds32 is designed to be very intuitive to use. Take a few minutes to understand the various functions, and within a very short time, using the ds32 will become second nature. You will be able to feel and hear, rather than have to look at the keys and display.

The Quick Reference guide on Page 5 provides a summary of the Control keys and Display Indicators on the ds32. Details of each Control and Display function are provided in the following pages.

It is suggested that you first familiarize yourself with operating the ds32 without wearing the headphones. Get comfortable with the layout and operation of the Controls. Then do some listening with the ds32, operate the Controls, and listen to the effects of the various operating modes and functions.

Control Ergonomics

The Control keys are designed to be operated by the thumb and forefinger of the left hand, as shown.

Operate the controls with firm pushes on the keys. The keys are designed to require a modest amount of pressure, in order to avoid accidental switching.

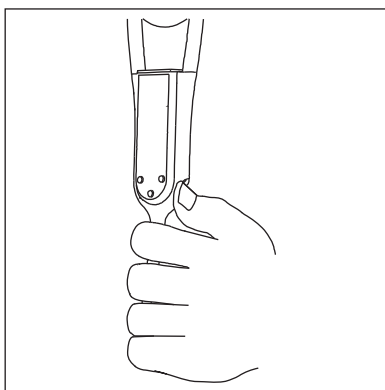
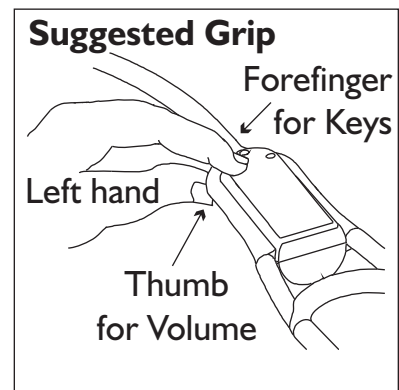



The Volume Control is located behind the Power/Zoom Key. It is designed to be operated by the left thumb as shown in the illustrations, leaving fingers to control the keys.

The exact grip and position is a matter of personal preference, and should be adjusted for comfort and ease of operation.



Power On/Off

Power On

Push and Hold the  key for about 1 second. When all LEDs light up, release the  key. (The delay is intended to prevent accidentally powering on the ds32.)

Power Off

Push and hold the  key for a few seconds until all LEDs light up, then release.

Auto Shut-Off

The ds32 will power down automatically after 120 seconds. It is therefore not necessary to manually turn off Power.

The  key has the dual function of controlling the  function, as discussed on the next page.

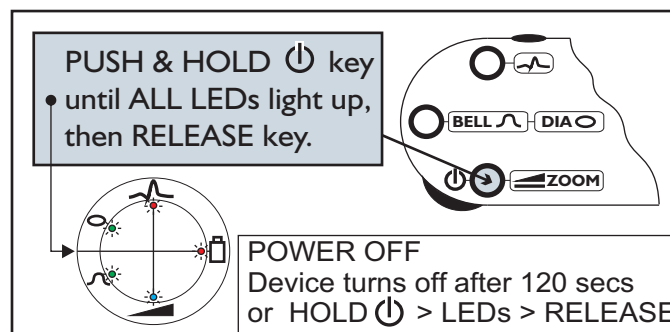



Zoom and Volume Control

To alternate between Zoom and Acoustic modes, push the  key:

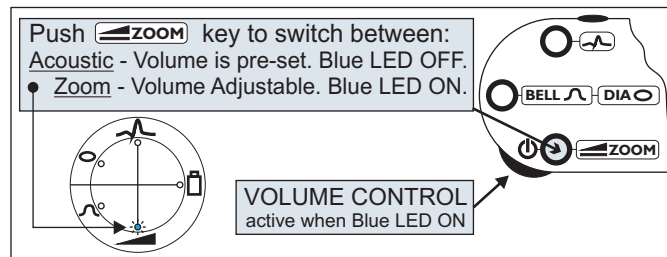

Zoom mode - Augmented sound, Volume is Adjustable - BLUE LED On

Volume is ADJUSTABLE with the Volume Control located behind the Control Panel. This allows the user to augment or “zoom in” on body sounds i.e. magnify signals to discern more detail, analogous to zooming in on an image.

Acoustic mode - Volume is Pre-Set - BLUE LED Off

Provides PRE-SET Volume similar to a conventional acoustic stethoscope. The ds32 still performs electronic signal processing in Acoustic mode, and you will notice the resulting clarity of signals in Acoustic mode. However, the sound characteristics in this mode are set to be similar to an acoustic stethoscope, so that users can compare standard and boosted sounds, such as during the grading of murmurs. This provides the “best of both worlds”, with access to both acoustic and boosted sound characteristics in one device.

Volume Settings and Psychoacoustics

It is suggested that volume levels be varied when listening to each patient. Body sound characteristics and detail change as the signal is zoomed to different volume levels. Sounds also vary with Probe position, age and obesity of patients.

The human auditory system “masks” quieter sounds with louder sounds. This is often a problem when using a conventional stethoscope, where louder heart sounds mask quieter sounds such as murmurs, and there is no way to control volume. By listening to the same sounds at different volume levels, auditory masking can be exploited, rather than being a limitation. At low volumes, masking will help to hear only certain louder sounds and quieter sounds will be masked. At higher volume settings, the ds32 will allow the auditory response to overcome masking effects to hear low-amplitude murmurs “through” the louder sounds. Volume levels from 5-8 are usually optimal. Some users might prefer to use the pre-set Acoustic mode for most listening, using the Zoom mode when further signal detail is required.

Warning - Protect your Hearing: Permanent hearing loss or Tinnitus can result from exposure to high sound pressure levels. Threshold shift (adaptation to high volume) makes loud sounds seem normal. Use caution when listening at high Volume, and limit exposure to loud sounds.



Bell-Diaphragm Mode

To Alternate between Bell and Diaphragm Modes, push the   key:

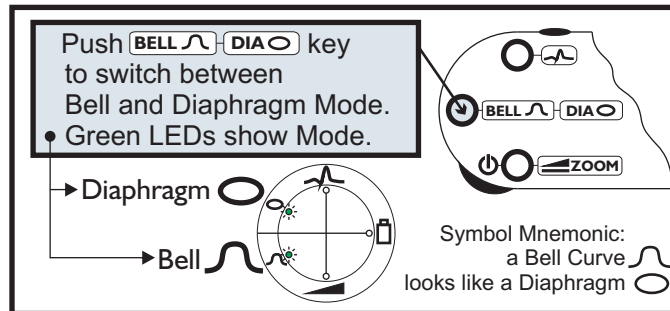

Diaphragm Mode - provides frequency response suited to valve and breath sounds. Diaphragm Mode will remove low frequencies, making it easier to discern higher frequencies that may be masked by the louder low frequencies.

Bell Mode - provides boosting of very low frequencies to facilitate listening to heart murmurs. Due to the substantial low frequency energy in some heart sounds, Bell Mode has significantly higher signal power than Diaphragm Mode.

The choice of Mode for any given diagnostic situation is a matter of listener preference, and alternating between modes helps to discern the nuances of body sounds.

Auscultation - a Pathology-Physiology Dichotomy

There is a dichotomy between the frequency characteristics of cardiac pathology and the physiology of human hearing. Many pathological heart sounds have significant low-frequency content. Unfortunately, human hearing is most inefficient when detecting such low frequencies. This dichotomy helps to explain why pathological sounds can be so difficult to discern, especially with a conventional acoustic stethoscope.

Much of the energy in a heart sound is in the frequency range below 100Hz. At the low sound pressure levels of a conventional acoustic stethoscope, a sound at 30Hz, for example, would be perceived as 40 decibels softer than a sound at 200Hz, even if both signals had the same power. In other words, the ear is 40dB (100 times) less sensitive at 30Hz than at 200Hz. The combination of low-amplitude and low-frequency can thus result in heart sounds that fall below the threshold of human hearing, making some pathological sounds essentially inaudible.

The ds32 reproduces very high audio power levels in the low-frequency range when compared to an acoustic stethoscope, raising the power at these frequencies above the human hearing threshold. In particular, Bell Mode is designed to provide significant power boost in the low-frequency range.

The Rhythm stethoscope's ability to reproduce low bass heart sounds explains one of the reasons the Bass Clef appears in the Rhythm logo.



Sync Indicator

To Enable the Sync function, push the  key.

To disable the Sync function, push the  key again.

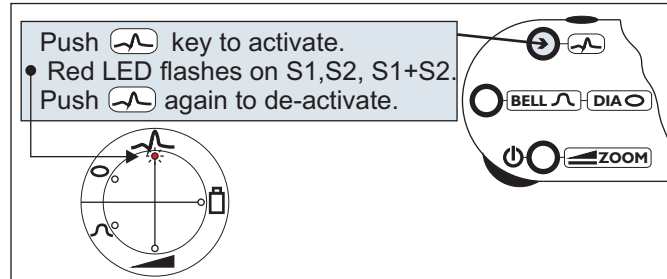

The Sync function is useful for learning cardiac signal timing. The Sync Indicator will flash when a peak occurs in the heartbeat signal, subject to location of the Probe. When the Probe is over the apex of the heart, the peak Sync indication will usually occur on the S1 heart sound. When the Probe is placed higher up on the chest, the peak Sync indication will occur on the S1 or S2 heart sound, and in some locations might indicate both S1 and S2. The Table below shows the detection system’s bias towards S1 or S2 subject to Probe location.

Location	Most Likely Sync Indication
Mitral/Apex	S1 is usually detected over S2.
Tricuspid	S1, S2, or both S1 and S2 are indicated.
Other locations	S1 is usually detected over S2.

When Sync is active, you may hear a faint “ticking” sound signifying the detection trigger of the Sync Indicator.

Using Sync

To detect and display cardiac timing, the ds32 performs complex signal processing and analysis of the auscultation signal. Reliable detection of cardiac cycle timing using only sound (without EKG) is subject to variations between patients, heart rate, and especially to the location of the Probe on the patient, since the first and second heart sound characteristics change based on Probe position.

In order to perform reliable detection, it is suggested that the Probe is placed lightly but firmly on the patient, and held in a steady position. Place the probe in locations that are least affected by chest wall motion, body hair, and body fat, which all tend to attenuate the cardiac signal. The detection system takes a few seconds to “lock in”, so place the Probe and wait for 2-3 seconds to observe the Sync LED. If detection is consistent, the location is suited to cardiac timing detection. If the indication is inconsistent, try a different position. In some cases, the carotid artery provides good timing signals.

The Sync Indicator is not affected by operating Modes or Volume control level.



Input/Output Port

An Input/Output Port is provided on the ds32.

The connector is a 2.5mm 4-position jack:

1. Signal Ground.
2. Serial Digital Output
3. Serial Digital Input
4. Analog Input/Output

Use only Thinklabs-supplied cables. Do not try to use 2.5mm plugs with less than 4 conductors. While such plugs fit into the jack, they will short-circuit some of the signals on the Port.

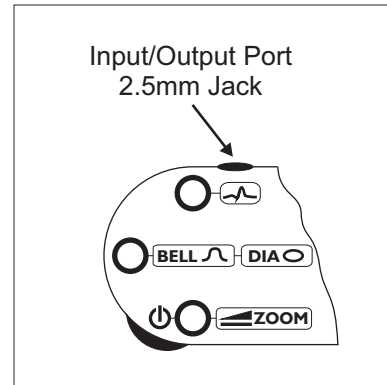

Using the Audio Input/Output Port

Analog Input - The Analog port can be used as an Input when the ds32 is powered OFF. This provides the following functionality:

- **Dual Listening** - Connect two Rhythm stethoscopes together. Turn one ds32 ON to be used as a stethoscope, and turn the second ds32 OFF to be used as a second listening device. This is useful for teaching purposes. A Thinklabs dual 2.5mm-plug cable is required.
- **Headphones** - Turn OFF the ds32, and use it as a set of high quality sealed headphones for listening to recorded auscultation sounds. Connect the ds32 to the headphone output of any audio device such as a PC, MP3 player, or CD player. The ds32 headphones are very sensitive, and will often reproduce noise from the connected device that may not be audible with conventional headphones. Neither the ds32 nor the equipment is faulty - simply use very low noise audio equipment or sound cards with the ds32. The ds32 headphones are mono, and are optimized for low/mid-frequency (body sound) reproduction.

Warning: Sounds levels can be extremely high due to the sealed eartip design of the ds32.

Analog Output - The Analog output provides a line-level signal for recording body sounds on external portable devices, such as notebook computers, PDA's or Digital recorders. Connect the ds32 to the Mic or Line Input of the recording device. When recording, make sure that the recording levels are set appropriately, so that signals from the ds32 are not "clipped" or otherwise distorted. Recorded sounds can then be played back through the ds32 headphones, as described above. Note that Volume and Bell/Diaphragm settings affect the Output signal.

The same cable can be used for recording and playback. When recording, the cable is connected to the recording equipment Mic/Line Input, and during playback to the Line or Headphone Output.

Notes:

1. **Warning: When used as a stethoscope, do not connect the ds32 to mains grounded equipment. Use only with portable devices operating on batteries.**
2. Contact Thinklabs for accessories and connection cables. **Do not use cables or connections provided by third parties.**
4. Contact Thinklabs for information regarding software and equipment interfaces to the ds32 serial Port.



Optimizing the ds32

The ds32 can be fine-tuned to each user's preferences. Take the time to read this section, and learn how to maintain and optimize your ds32 to get the most out of using your stethoscope.

General Maintenance and Cleaning

- Do not immerse the ds32 in any liquid. If the ds32 is inadvertently immersed in liquid, do NOT Power ON the unit. Completely dry out the inner spaces before trying to use the ds32 again. Contact Thinklabs for assistance.
- Do not sterilize the ds32 using any sterilization process.
- Wipe the ds32 with alcohol swabs or a soft cloth moistened with alcohol or water. Do not use abrasive cleaning agents, and do not allow fluids to enter the device.
- Avoid extreme heat, cold or humidity for either storage or use of this device. -4F to 110F (-20C to 43C) storage. Room temperature is recommended for use. Note that closed vehicles reach well above 120F in summer.
- Wearing the ds32 on the shoulders is preferable to tightly folding the device and placing it in a jacket pocket.
- Avoid excessive force applied to any part of the device. Damage could result.
- Avoid dropping the ds32 on hard floors, especially concrete. Damage could result.
- Remove batteries if device is not to be used for a period of months.
- See Tips and Troubleshooting, Page 24, for more information.

Damage resulting from inappropriate care of the device may compromise product performance or void the Warranty.



Eartip Adjustment

The headphones are designed with soft silicone eartips. Adjustment of the eartips and the headphones will ensure that optimal comfort and fit is obtained. See also Eartip Cleaning and Replacement, Page 23.

When using the ds32, the **eartips should be pointed forward**.

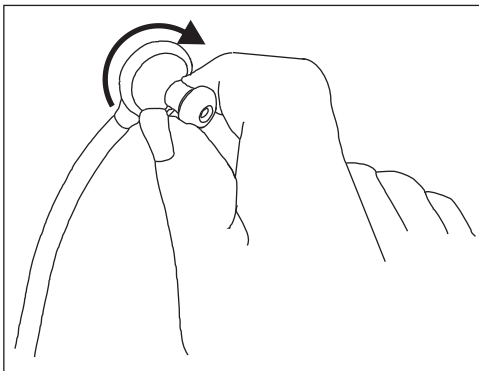
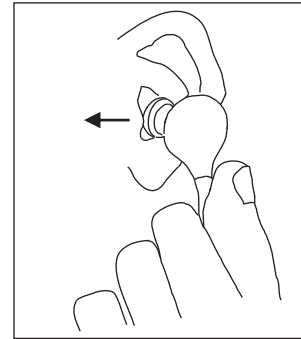
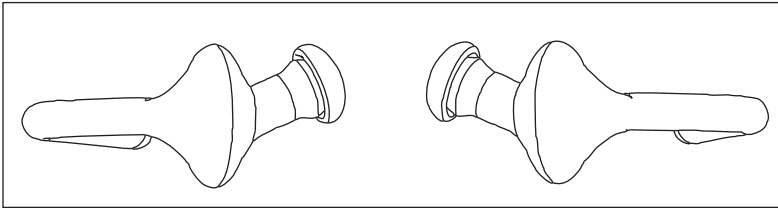

To adjust the eartip angles, grip the solid eartip shafts, as shown, and **rotate clockwise** to the correct angle. Do **NOT** rotate anti-clockwise. This may loosen the headphone assembly. Do not force.

This adjustment has been done at the factory and should not be necessary when the ds32 is new.

Both eartips should be at the same angle, and the headphones should be aligned symmetrically as shown, such that the eartips and headphones are mirror images. This may require than the headphone arms be pushed **forward and back** (one forward, the other back) as shown by the arrows, to **align** the spring. This adjustment may be required from time to time to maintain alignment and comfort.

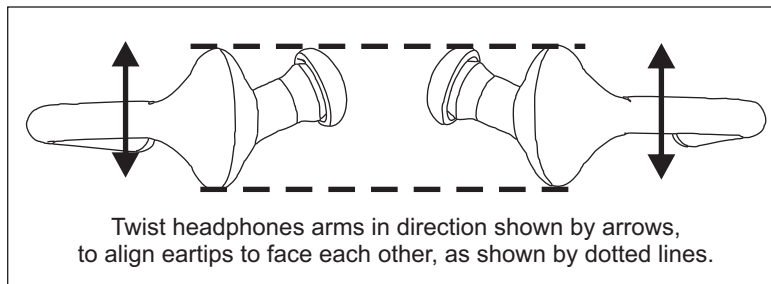



Headphone Adjustment

Use two hands!

To maintain headphone comfort, fit, and alignment, use both hands to insert and remove headphones. Do not “rip” headphones from the ears using one hand.

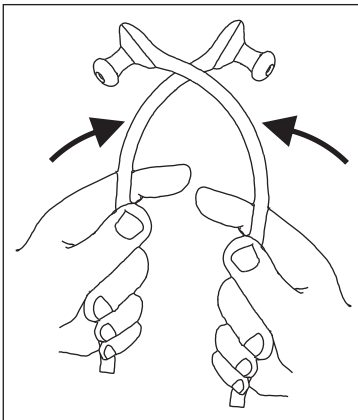
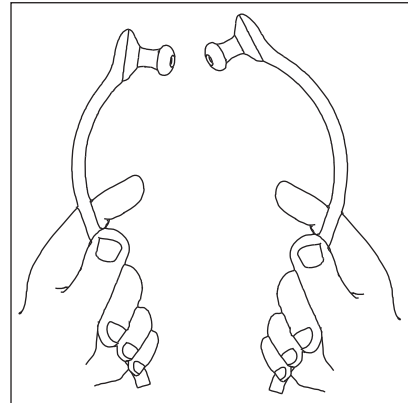

Increasing Headphone Tension

If increased headphone spring tension is desired, close the headphone arms beyond their normally opened position a few times, crossing the metal tubes, and test for comfort and fit.

Although it has been customary in the past to adjust stethoscopes with very tight fit, the amplification of the ds32 and the design of the eartips allows for very light pressure to produce an excellent sound seal.

Decreasing Spring Tension

To decrease spring tension, open the headphones beyond their normal position and test for comfort and fit.

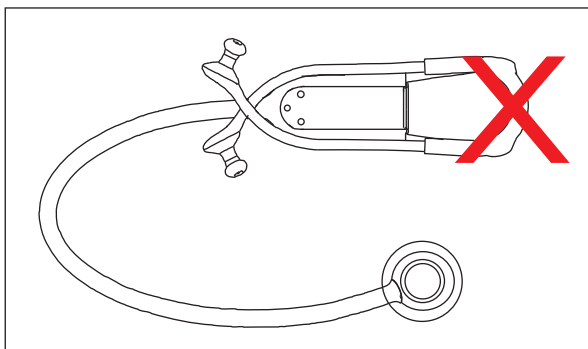
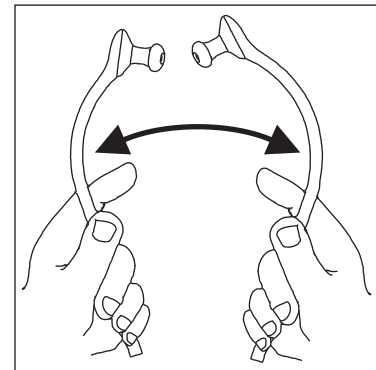

Folding and carrying the ds32

Tightly folding the stethoscope at the headphones to place in a jacket pocket is discouraged. While the ds32 is designed to fold as shown, wearing the ds32 on the shoulders is a more benign practice, inflicting less wear on the stethoscope.



Listening with the ds32

The ds32 Probe uses Electromagnetic Diaphragm (EmD) technology which has some important characteristics that should be understood to achieve optimal performance:

- a. Pressure - The Diaphragm is pressure-modulated i.e. pressure controls the mechanical and electrical parameters of the EmD sensing system thereby changing the frequency response. The user can significantly alter the sound by adjusting diaphragm pressure. Learn how to use this to advantage during patient examination.
- b. Low-Frequency Response - The EmD system is designed to be sensitive to sub-sonic frequencies. This is important and useful for murmur and bruit detection. This can also make the EmD somewhat sensitive to other sub-sonic signals such as chest wall motion and operator hand movement. Learn how to avoid sub-sonic artifact to achieve optimal sound. (See also Diaphragm Selection, Page 19).

Diaphragm Pressure and Frequency Response

Apply the Probe to the chest, make subtle changes in diaphragm pressure, and listen to the effects. The following control is possible:

- Light Pressure - low-frequency sounds are enhanced for listening to heart sound, murmurs and bruits that are low-pitched.
- Moderate Pressure - low-frequency sounds are attenuated. This is suitable for attenuating heart sounds and listening primarily to lung sounds.

Within a short time, it should become intuitive to adjust the Probe/diaphragm pressure for a particular examination. Do not apply excessive diaphragm pressure. This will severely cut the sensitivity and free motion of the diaphragm.

Holding the Probe - steady pressure reduces sub-sonics

The EmD150L Diaphragm* detects signals in the sub-sonic frequency range, to reproduce quiet low-frequency heart murmurs. Patient chest wall motion, or unsteady examiner hand motion, can induce large-amplitude sub-sonic vibrations. This can overload the detector and produce signal artifact or cutout. Apply steady pressure to avoid these problems.

It is helpful to hold the Probe so that the fingers holding the Probe also touch the patient chest wall (such as the left edge of the thumb and the fingertips in the figure.) The Probe and chest wall then move in unison, with a consistent, light diaphragm pressure. Alternatively, the “flat palm” grip (palm flat, Probe between fingers) will also serve to ensure that chest wall and Probe move in unison.

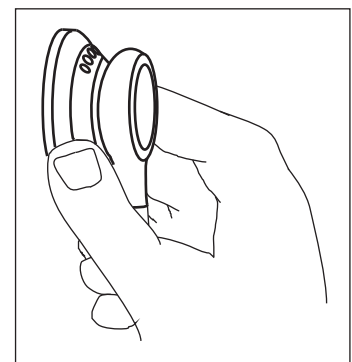

* The EmD200L diaphragm has lower sub-sonic sensitivity, and has greater immunity to motion artifact.



Diaphragm Selection

The ds32 is shipped with 2 different diaphragms, each with unique acoustic characteristics. Try each diaphragm, and use the one that suits your medical practice and personal preferences. See also Diaphragm Cleaning & Replacement, page 20.

Model	EmD200L (factory default)	EmD150L (accessory)
Overall Sensitivity	Medium	High
Low Frequency Sensitivity	Medium	High
Immunity to motion artifact	High	Medium
Immunity to ambient noise	Good	Better
Pros	<ul style="list-style-type: none"> ● Medium-level sensitivity suited for most medical- practice use, blood pressure measurements, pulmonary, etc. ● Less sensitive to operator or patient movement. ● Easy to learn, easy to use. 	<ul style="list-style-type: none"> ● High sensitivity useful for very low-amplitude sounds, obese patients, etc. when maximum performance is desired. ● High sensitivity to ultra low frequencies helpful for heart murmurs.
Cons	<ul style="list-style-type: none"> ● Medium-level sensitivity throttles back a little on performance for those seeking high sensitivity. ● Slightly more sensitive to ambient noise. 	<ul style="list-style-type: none"> ● Higher sensitivity to operator or patient movement requires more steady contact. ● Takes a little time to get used to such high sensitivity after using an acoustic stethoscope.
Recommendation	Start with this diaphragm. "Medium-sensitivity" is still very high performance.	If you want to push the performance envelope, try this diaphragm. You may prefer higher sensitivity.

The Diaphragm - fine-tuning your stethoscope sound

A key aspect of Thinklabs stethoscopes' high performance is the patented Electromagnetic Diaphragm (EmD). Diaphragm motion is measured electronically and converted directly into an electronic signal. This opens up a new level of acoustic control, such that the audio characteristics of the stethoscope can be very carefully fine-tuned through design and materials selection. Think of the diaphragm as the equivalent of the wood used on an acoustic musical instrument.

Our initial thinking was that we would fine-tune the diaphragm design in the lab to achieve an "optimal" sound characteristic. However, we realized that, like owners of a fine musical instrument, users will have personal preferences. It would be more beneficial to give users a choice in the tonality and acoustics of their instrument.

By providing two diaphragms, each user is able to customize the sound of his/her stethoscope according to personal preference, sub-speciality and medical practice requirements, and other criteria. This research continues, and as users develop preferences and discover clinical benefits of various acoustic characteristics, new ds32 diaphragms might be offered. User feedback is an important part of this process. Contact Thinklabs with comments and feedback.



Diaphragm Changing and Replacement

The Electromagnetic Diaphragm (EmD) requires replacement if:

- The Diaphragm is being swapped to a different model diaphragm to adjust acoustics.
- The Diaphragm is damaged or contaminated.

To replace the Diaphragm

Always use a Thinklabs Electromagnetic Diaphragm (EmD). Conventional stethoscope diaphragms will not work on the ds32.

Never open the ds32 in a dusty environment. Do not allow dust, lint or excess moisture to enter the Probe. For best results, change the diaphragm in a clean, dust-free environment, such as a medical examination room, or other clean environment.

- Unscrew the diaphragm ring and remove as shown. (Direction - unscrew anti-clockwise when looking directly at the diaphragm).

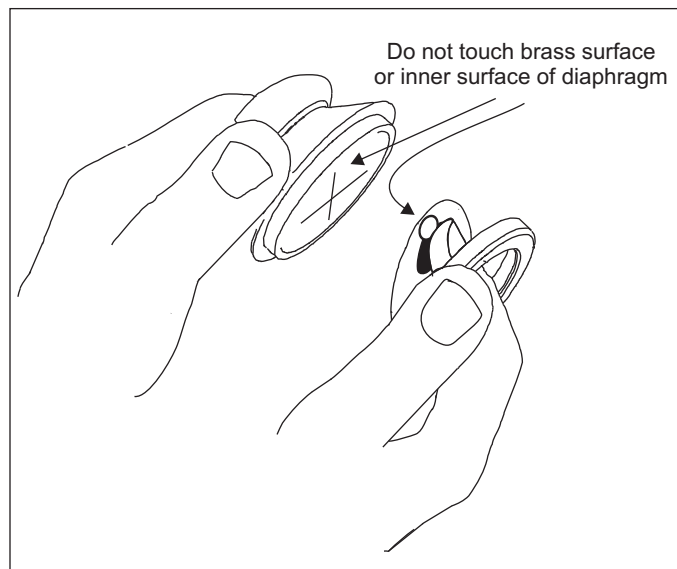

Avoid touching the brass plate or the inside surface of the diaphragm. These surfaces are sensitive, and surface contamination can compromise performance, or cause permanent damage.

- Place the new diaphragm in the diaphragm ring, with graphics facing out, and re-attach the diaphragm ring. Do not over-tighten the diaphragm ring.

If problems occur after replacing the diaphragm, see
Probe Maintenance, Page 21,
Tips and Troubleshooting, Page 24.



Probe Maintenance - ensuring low-noise performance

The EmD sensor sets up has a high-voltage electric field in the space behind the diaphragm. Diaphragm movement modulates this field, such that extremely small vibrations of the diaphragm are directly detected as field changes. For proper operation, the space in which the field exists must be clean and dust- and lint-free, and not contain excess moisture.

Under normal circumstances, the field will remain clean, and require no maintenance. However, if dust, lint or moisture do enter the Probe, unexpected background of louder noises can occur. The simple cleaning procedures below can then be used to rapidly re-establish noise-free operation, using a standard alcohol swab. These procedures are described in great detail for clarity. However, they are simple, and take less than 2 minutes to complete.

Noise Symptoms

Dust, lint or moisture in the field produces the following possible symptoms:

- intermittent faint white-noise.
- squealing sounds, either faint or more prominent.
- ticking sounds (static discharges).
- above artifact sounds change when the diaphragm is pressed or unscrewed slightly.

If you notice any of these symptoms, follow the cleaning procedures below. If your ds32 is operating well, these procedures are not required for regular maintenance.

Alcohol Cleaning

- Make sure the unit is turned off.
- Unscrew the diaphragm as described on the previous page. **Open the probe in a clean, dust-free environment, and place the open part of the probe face-up. DO not touch the brass plate. Do not place the open probe on a dusty surface or a cloth surface.** Lint could be attracted into the Probe.
- Using a lint-free alcohol swab, carefully wipe the inner surface of the diaphragm as shown. Do not touch the inner plastic surface of the diaphragm with anything other than the alcohol swab.

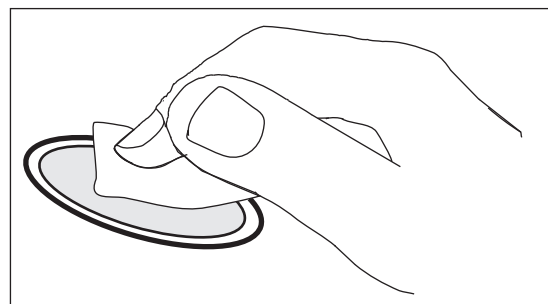

(Continued on next page)



Probe Maintenance (continued)

- Using the alcohol swab, carefully wipe the brass plate inside the Probe. **Do not touch the brass plate. This could permanently damage the sensor.**

- Allow the diaphragm and probe surfaces to dry by evaporation. Do not close the unit and power it up with alcohol moisture on the diaphragm. Only after evaporation will the surfaces be clean and ready for use.

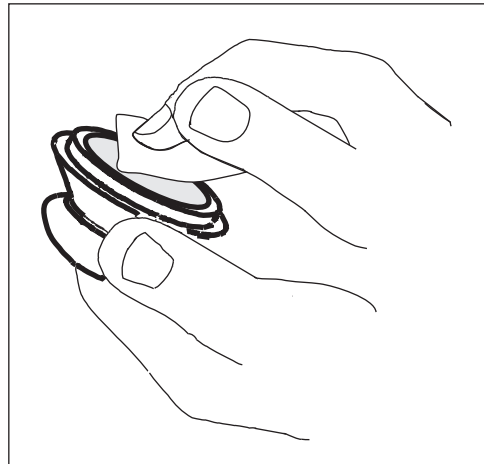

Air Drying and Cleaning

The probe can further be cleaned using a dry air aerosol spray. These are available at hardware or office supply store, and are usually used for cleaning computers. This cleaning method is useful when the unit has been exposed to extreme dust, lint, humidity or moisture, or in addition to the alcohol-swab cleaning described above, the rare instance that contaminants exist inside the probe.

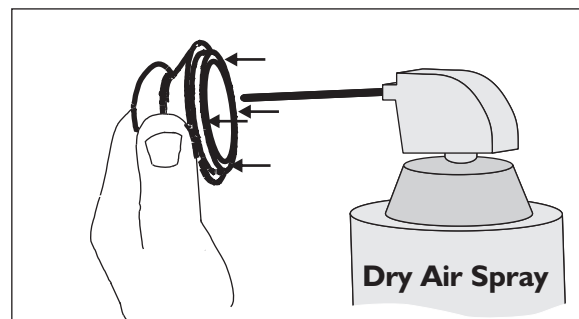

- Make sure the unit is turned off.
- Rotate the Aperture Ring to the open position (see page 8) to allow air flow in the Probe.
- Unscrew the Diaphragm Ring and remove the diaphragm. Place the diaphragm with Thinklabs logo face DOWN, so the inside surface does not become dusty.
- Using the dry air spray with the spray's plastic straw, spray the inside of the probe via the vent holes in the Aperture Ring, and around the circumference of the brass plate. Do not touch the brass plate with anything, including the plastic straw. Do not overspray. White condensation sometimes forms, which is counterproductive when trying to dry out the Probe.
- Replace the Diaphragm, and close the Aperture Ring. Wait a few minutes for the Probe to stabilize, and then power up the unit to test.

If these cleaning procedures do not correct the problem, see Tips and Troubleshooting, Page 24, and contact Thinklabs.



Eartip Cleaning and Replacement

The eartips can be removed for cleaning or replacement.

To remove eartips, grip the eartip between thumb and forefinger as shown, and (a) pull the eartips off in a straight line or (b) gently twist the eartip off the eartip shaft. Do not use excessive force.

To replace eartips, gently push the eartip over the eartip shaft into position. Do not use excessive force.

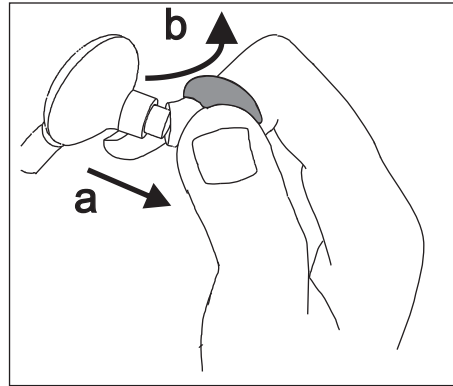

Quick Clean

Without removing the eartips, use a **slightly damp** soft cloth or alcohol swab to wipe the eartips. Never allow fluids to enter the speaker housings.

Thorough Clean

- Remove eartips for cleaning.
- Clean the eartips with non-abrasive cleaning materials. Alcohol or gentle soap and running water are recommended. (Don't lose the eartips down the drain.)
- Rinse off cleaning agent thoroughly and dry.
- Re-attach the eartips.

When the eartips become worn, contact Thinklabs or go to the website for replacement eartips.

To Adjust Eartips for comfort and fit, see Eartip Adjustment, Page 16.



Tips and Troubleshooting

Your ds32 is designed, built and tested to provide you with excellent sound quality and performance. If you have any questions, comments, suggestions or experiences you would like to share, please let us know at service@thinklabsmedical.com. We will respond to all emails. If you have a problem requiring more immediate attention, please call us.

Before contacting us, we suggest that you read relevant sections of the User's Manual, read this section of tips and troubleshooting suggestions, and look at www.thinklabsmedical.com, where we will place FAQ's, updates and useful information for Rhythm owners.

Get the most out of your ds32 - Most users do not read User's Manuals. We have tried to provide additional information and tips in the Manual to help you get the most out of using the ds32. In particular, read the following sections:

Optimal Use of the ds32	Page 4
Probe Setup	Page 8
Control Ergonomics	Page 9
Volume Settings and Psychoacoustics	Page 11
Auscultation - a Pathology-Physiology Dichotomy	Page 12
Listening with the ds32	Page 18
Diaphragm Selection	Page 19

The ds32 does not Turn On

- Check the Battery polarity (page 6). The wrong polarity can cause damage to the ds32.
- Batteries may need replacement. Follow instructions on page 6.
- You are not Holding the Power key long enough to see all LEDs light up, and then releasing the key. If the device does not power on, execute this keystroke sequence again, until LEDs light (page 10).

The ds32 is not producing any sound

- No sound in Zoom mode (when Blue LED On). Increase the Volume setting. It may be set at a very low level. Set Volume to say, '7', and try again.
- Check the headphone fit. Do you have the ds32 on backwards and the eartips are facing the wrong way? The eartips should face forward, and the control panel should face forward. Check the adjustment of the eartips. See pages 16-17.

The ds32 is producing unexpected interference or noise

The ds32 should provide a low-noise, high-quality signal. If used on clothing or not applied correctly to the patient, artifact can be produced. Simply apply the Probe as recommended, making good contact with the patient. There are some interfering noises that can occur even when not examining a patient. Some potential culprits are listed below, with remedies:

- Radio stations or electromagnetic pickup: Move the ds32 to a location that does not have strong electromagnetic fields from such sources.
- Continuous loud buzzing: The diaphragm is loose. Tighten the diaphragm retainer ring.
- Continuous loud buzzing: The ds32 is connected to mains-powered or grounded equipment. If you have the ds32 connected to an external device, is the device powered by mains electricity or on a wired network? If so, disconnect the other cables from the equipment, so that the ds32 is connected only to "floating" (ungrounded) device.
- Other noise: Dust or moisture may exist inside the Probe. See Pages 21, 22.
- Problem unsolved? Contact Thinklabs for assistance. (See page 26 for contact information).



Tips and Troubleshooting (continued)

Headphones do not fit correctly or are uncomfortable

- Are you wearing the headphones the right way? The eartips should face forward, and the Control Panel should face forward.
- Eartips or headphones are out of alignment (page 16).
- Headphone spring tension isn't correct (page 17).

Sound is sometimes distorted or cuts out temporarily when listening

- Volume is too high. Reduce Volume level or try Acoustic mode (page 11).
- Probe is not being held in a firm and steady position, or is not being held with a steady pressure against the patient. The ds32 EmD diaphragm can sense frequencies down to the sub-sonic range, in order to cover the whole audio spectrum for murmur detection. Vibrations caused by patient or user hand movement are also sometimes sensed as loud signals that distort body sounds. Hold the Probe steady with a light but consistent pressure against the patient. It sometimes helps to hold the Probe so that the fingers holding the Probe also touch the patient chest wall, so that the Probe and chest wall move in unison.

Heart sounds on some patients are difficult to hear

Heart sounds are attenuated in obese patients. When patients have substantial body hair, this reduces the contact of the diaphragm against the body. Similarly, clothing can sometimes reduce sound transmission. This is a matter of physics, and in such circumstances, conventional stethoscopes are usually not effective. To overcome such limitations, try and ensure that the EmD diaphragm is making good, direct skin contact, preferably in a location that has less body fat or hair to cause attenuation. Do not apply excessive pressure on the Probe. Preferably, apply a light but firm pressure, so that the low-frequency sensitivity of the ds32 is optimized, and the diaphragm is making full contact with the patient.

Working in high ambient noise environments

Rhythm stethoscopes are designed to attenuate ambient noise. To optimize this attenuation:

- Do not listen through clothing.
- Ensure that the diaphragm is making good contact with the patient.
- Apply light but firm pressure on the Probe. Do not press too hard.
- Adjust the Volume such that body sounds are audible, but avoid using such a high volume that ambient sounds become audible. There is usually an optimal volume setting for a given environment.
- If you are using the EmD200L Diaphragm, try the EmD150L, which has higher immunity to ambient noise. See Diaphragm Selection, Page 19.
- Experiment with the Acoustic Aperture (page 8). In high noise environments, it is suggested that the Aperture be kept open!

Wearing the ds32 - why shoulders and not pocket?

We do not recommend folding the ds32 into a small bundle and stuffing it into your jacket pocket. We know this is done with acoustic stethoscopes, and we've also designed and tested the ds32 to be folded that way. However, wearing the ds32 on the shoulders is a more benign practice, since it places less stress on the mechanical parts. It is therefore a highly preferred way to treat your stethoscope.



Service and Warranty

This product is warranted against manufacturing or materials defects for a period of one year from the invoice date. If a material or manufacturing defect occurs within the warranty period, repairs will be performed free of charge upon returning the device to Thinklabs. The warranty will be voided in cases of abuse, excessive or inappropriate use conditions, or accidental damage to the product. The warranty is transferable at Thinklabs' discretion only.

For maintenance, repair, service and contact information, visit the Thinklabs website at www.thinklabsmedical.com, and check the Support page. Before shipping the product for repair, please contact Thinklabs first, at

service@thinklabsmedical.com,
or (303)521-5023.

Please quote the serial number, located inside the battery compartment when contacting us.

To have the product repaired, ship the product in suitably protective packaging, with name, return address, daytime telephone number, a description of the problem, and a copy of the purchase invoice, to:

Thinklabs inc.
Attn: Service
6571 South Pontiac Court
Centennial, CO 80111

Package Contents

- 1x Rhythm ds32 High Resolution Stethoscope with EmD200L Medium-sensitivity Diaphragm
- 2x AAA Batteries
- 2x Spare eartips
- 1x EmD150L high-sensitivity Diaphragm
- 1x Quick Reference Guide
- 1x Reference CD with complete User's Manual



© 2004 Thinklabs inc. All rights reserved.

Thinklabs, the Thinklabs logo, Rhythm, the Rhythm logo, High Resolution Auscultation, Hear Everything in a Heartbeat, EmD, Electromagnetic Diaphragm, are all trademarks of Thinklabs inc. Centennial, CO 80111

<http://www.thinklabsmedical.com>

service@thinklabsmedical.com

303-521-5023

6571 South Pontiac Court
Centennial, CO 80111

Product Made in China for Thinklabs inc.

US Patents 6,498,854 6,661,897
Other US and Foreign Patents Pending.

Thinklabs Part no. ds32umpdf v1.1